



Installation Instructions - Supplemental

Commercial Pool Heater Application

for PRIMERA® Models 400W, 540W 750W, 1000W 1200W, 1600W and 2000W

Installation of the Commercial Pool Heater Package must be performed by a qualified service installer or service agency. These instructions are to supplement the Installation and Maintenance Manual provided with your PRIMERA water heater or boiler.

Before you begin, read and follow these instructions, as well as the information contained in the PRIMERA® Installation and Maintenance Manual. To obtain an additional copy of the PRIMERA® Installation and Maintenance Manual, or for any questions, call Riverside Hydronics, LLC at 1-800-990-5918.

WARNING: If the information in the supplied instructions and manual(s) is not followed exactly, a fire, explosion, exposure to hazardous materials or conditions or other hazards may result, causing property damage, personal injury or loss of life.

If the water heaters are to be installed outdoors, refer to supplemental instruction sheet 34-400.4 for information on outdoor vent kit.

ADDITIONAL PARTS REQUIRED FOR POOL APPLICATIONS

Following is a list of parts required for application of PRIMERA water heaters into pools: Refer to Figure 1 for their location.

- 1 – PN 57432 Thermostat, Honeywell #L4006A1678
- 1 – PN 14960 Well, Thermostat ¾" x 3" long Honeywell #121371B
(Requires a 3/4-inch fitting in the pool loop downstream of the water heater)
- 1 - TempTrac® Temperature Sensor Well:
PN 102560 Single-probe well (Requires a 1/2-inch fitting upstream of the water heater in the pool loop. Or
PN 102561 Four-probe well (For multiple pool heater applications, requires a 3/4-inch fitting upstream of the water heaters in the pool loop)

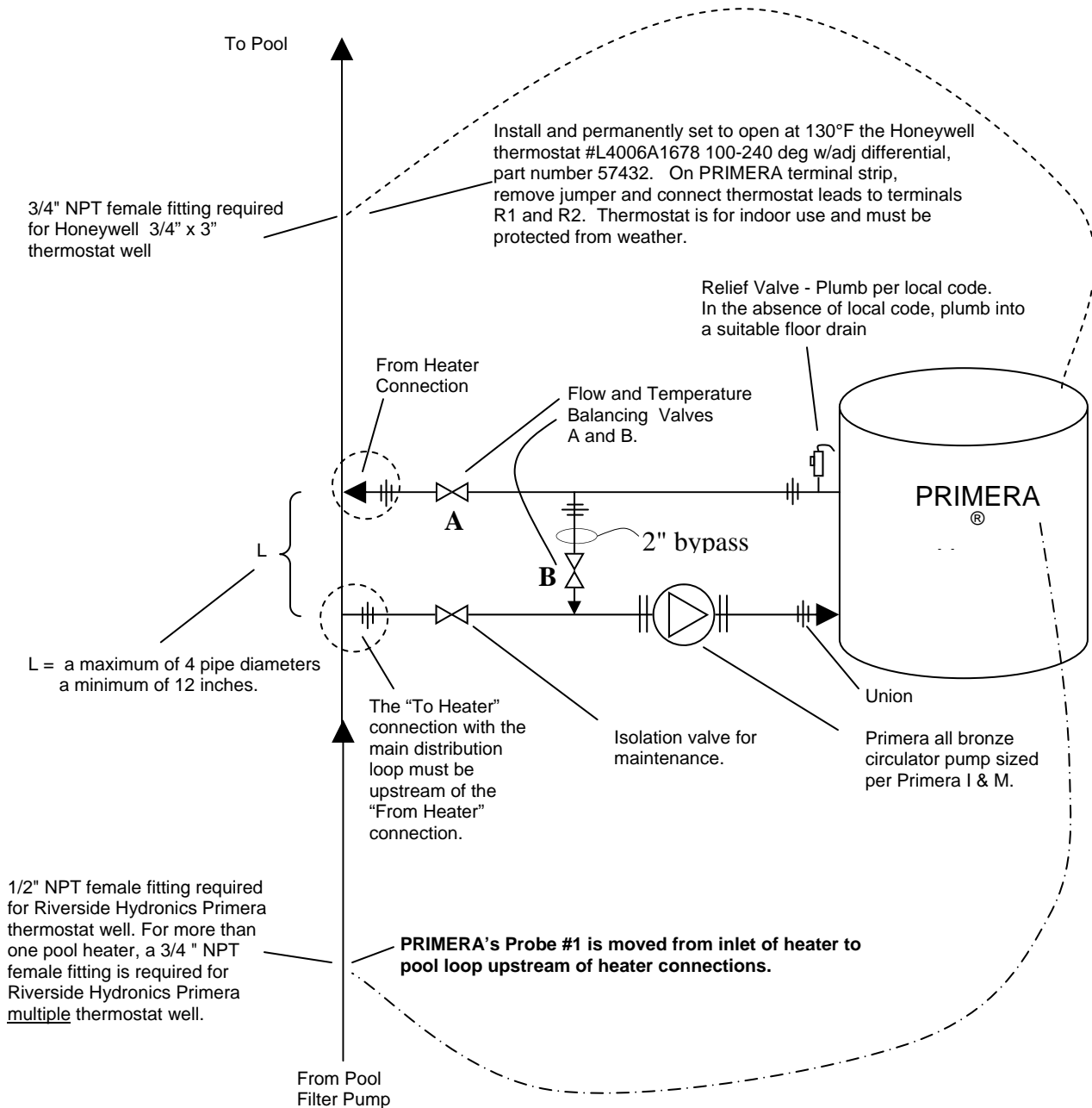
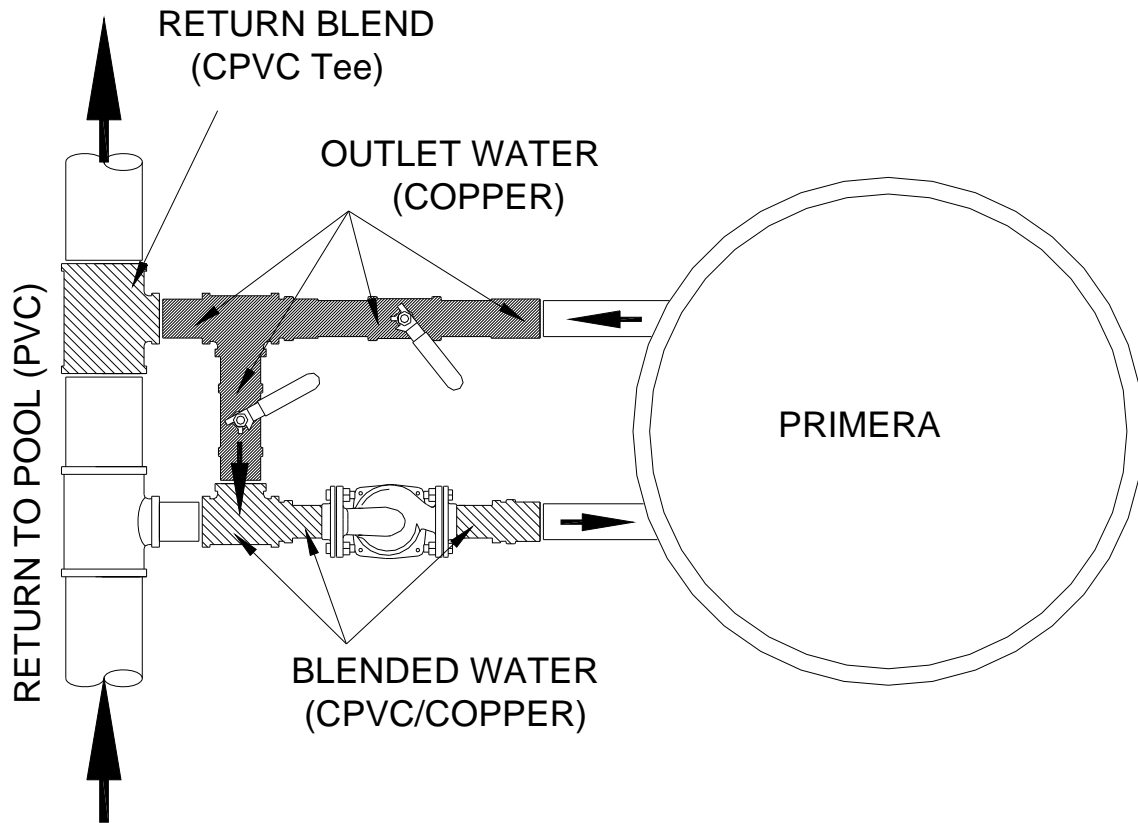

Figure 1: Piping and Component Location for PRIMERA Pool Heaters

PIPE MATERIAL

Although PVC is acceptable for plumbing water to the filter pump, it is not acceptable for plumbing the plumbing loop to the pool heater. The pool a loop consists of an unheated water leg (PVC is permitted here), a blended water leg (must be either CPVC or copper), and the outlet from the heater (must be copper only).

Refer to the figure below. Locate the "T" fitting directly upstream of the pump. This fitting, and the plumbing leading to the heater inlet (BLENDED WATER) must be plumbed of either CPVC or copper. Locate the plumbing from the outlet of the heater leading to the "T" fitting which blends water with water entering the heater (OUTLET WATER). This must be plumbed with copper. The T fitting which blends heated water with the return plumbing (RETURN BLEND) must be CPVC or copper.



APPLICATION GUIDELINES

The water heater must be ordered for single-stage firing only. Stage-fired and modulating water heaters will not function properly in pool heating applications due to the tremendous thermal mass represented by the water in the pool. Because this thermal mass gains and loses energy slowly, there is no advantage to modulating the energy input. For the same reason, lead-lag controls are not recommended on multiple pool heater applications.

The TempTrac operating control must be adjusted for the low temperature set points for pool applications:

- ST1 parameter must be set to desired pool temperature; for example 80 degrees.
- Hy1 parameter must be set to -2 (call-for-heat differential from ST1 parameter)
- LS1 parameter must be set to 50 (minimum setpoint for ST1)
- US1 parameter must be set to 108 (maximum setpoint for ST1)

Refer to TempTrac manual for instructions on resetting these parameters. (form 34-80)

Refer to Figure 1 for the following startup procedure. The low-temperature bypass must be sized at 2 inches with a full-port ball valve. This is because more than 1/2 the flow to the heater inlet will come from the bypass in this low-temp application. Temperature at the water heater inlet must be no less than 130 degrees and should be adjusted to no higher than 140 degrees.

FLOW SWITCH

Refer to figure above and locate the filter and circulator pumps in the diagram. The Primera water heater comes equipped with a flow switch that will only allow heater operation if the **circulator pump** is providing adequate flow for safe operation. If the pool heater operated while the **filter pump** was not operating, the water would quickly elevate to temperatures which would melt CPVC and PVC plumbing. A flow switch to prove operation of the filter pump (separate from and additional to the flow switch which comes standard on the Primera pool heater) must be installed per the manufacturers instructions. This will prevent the Primera from operating when the filter pump is not, thus preventing damage to plumbing. The flow switch should be installed in a long straight run of piping. See the following figure. Refer to the section entitled REWIRING THE POOL HEATER for instructions on how to wire the flow switch.

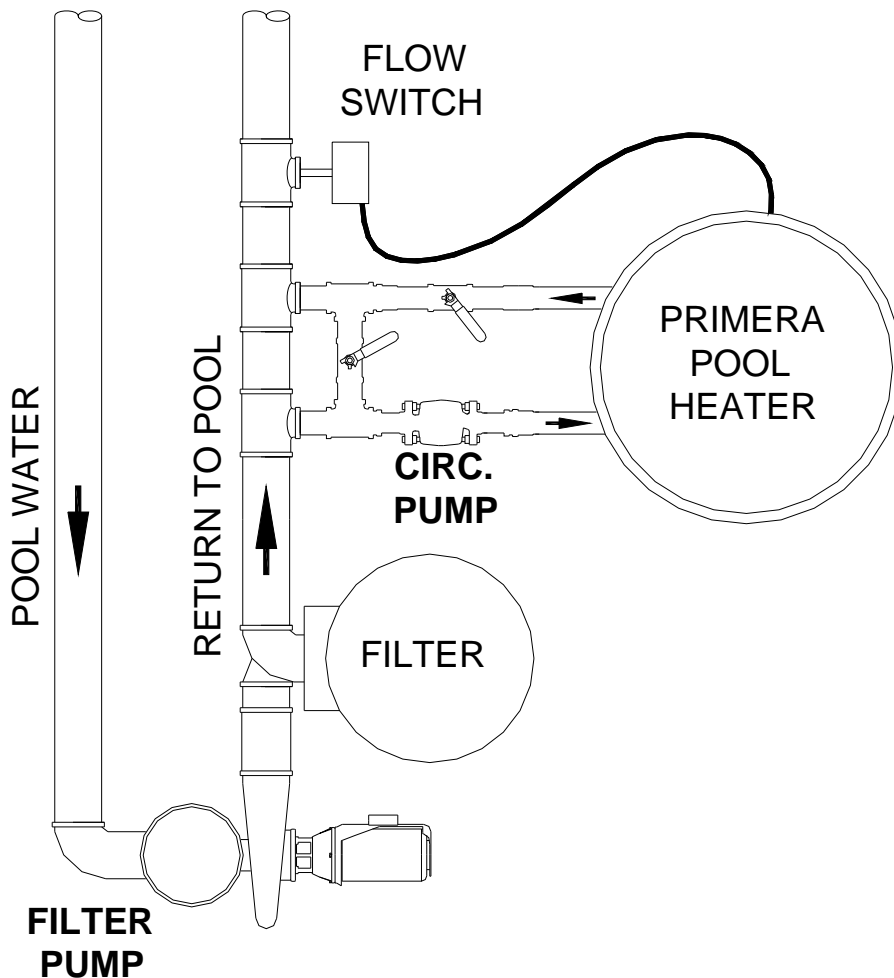

ELECTRICAL POWER FOR THE CIRCULATOR PUMP

Refer to figure above and locate the filter and circulator pumps in the diagram. Power must be supplied to the circulator pump so that it runs either continuously or on the same time clock settings as the filter pump. If the circulator pump is not powered continuously, air can accumulate in the pool heater which will prevent it from operating.

REWIRING THE POOL HEATER

For proper operation, the pool heater wiring must be modified so that the flow switch of the pool heater control circuit functions in series with the flow switch for the filter pump, interrupting the thermostat. Call Riverside Hydronics, LLC at 1-800-990-5918 regarding re-wiring the pool heater. Certain serial numbers are wired differently. Your Riverside Hydronics factory representative will assist you with these details. After your factory representative confirms the serial number is appropriate, re-wire the PRIMERA according the following steps and diagram.

Step1

1. Disconnect electrical power.
2. Remove the top panels to access the burner control region of the Primera.
3. Locate the leads to the pump proving switch. The pump proving switch is located in the 3" copper header inside the control jacket. On the Primera 400, the switch is located in the lower (inlet) header outside the jacket. There is a black cord set (2 leads) from the pump proving switch that terminates in the electrical enclosure of the Primera on the S1 and S2 terminals of the main terminal strip.
4. Remove the pump proving switch leads from the S1 and S2 terminals.
5. Locate the field access terminal strip in the upper right hand region of the electrical control enclosure. Remove the jumper wire between the R2 and C1 terminals.
6. Using the jumper that was removed from the R2 and C1 terminals, jump between the S1 and S2 terminals of the main terminal strip.

Step 2

1. Place the leads of the pump proving switch in series with the filter pump proving switch, across the R2 and C1 terminals of the field access terminal strip. Connect one lead of the Primera proving switch to one lead of the filter pump proving switch. Connect the other lead of the Primera to R2. Connect the other lead of the filter pump proving switch to C1. Refer to the following diagram.
2. Replace the jacket and or top panels and reconnect power.
3. Proceed with the STARTUP PROCEDURE.

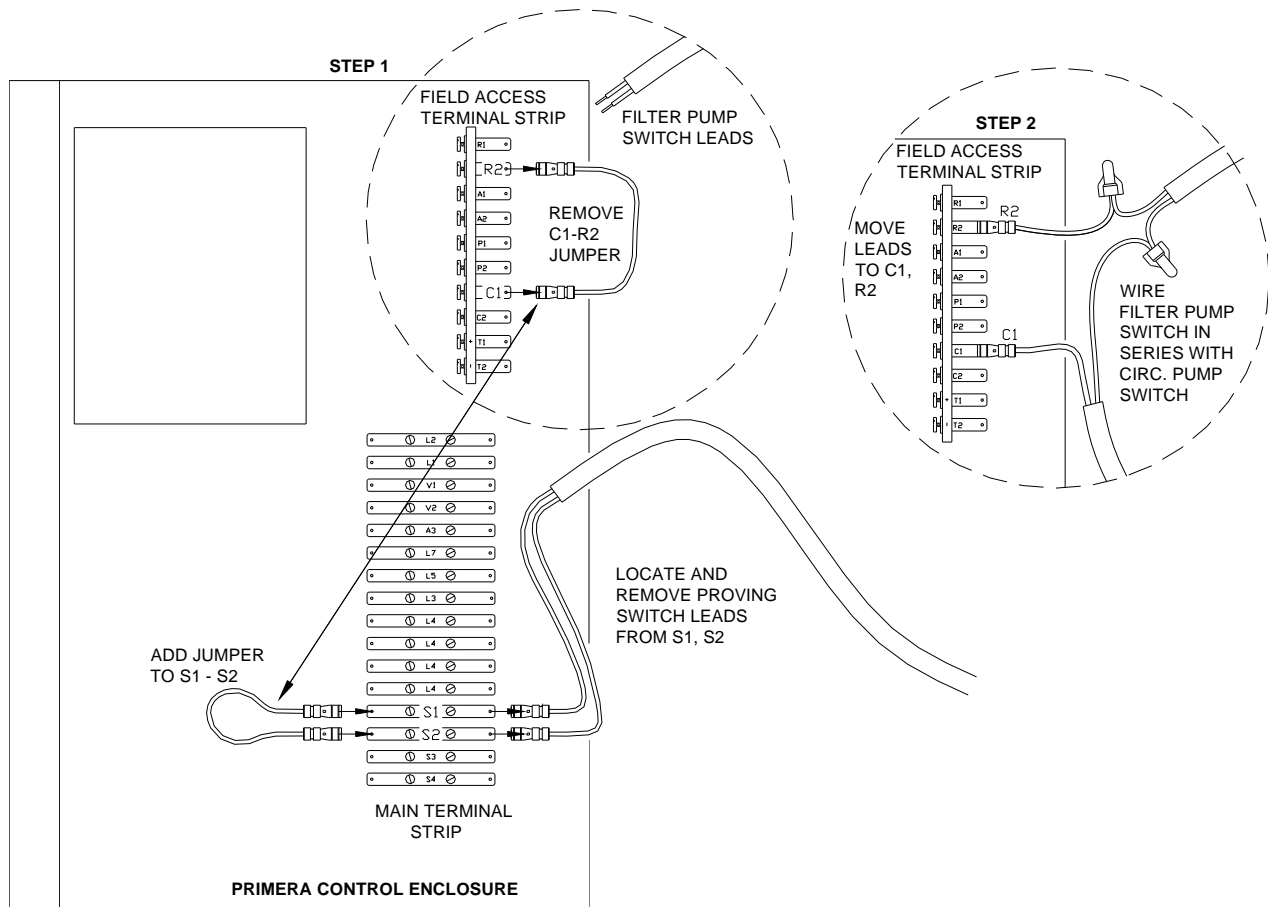

STARTUP PROCEDURE

1. Make sure PRIMERA temperature probe is in the inlet of water heater and not the pool filter loop for startup. This probe will be relocated to pool filter loop after startup procedure is complete.
2. Close manual bypass valve (B). Fully open the isolation valve on the inlet piping to the heater and the balancing valve on the outlet piping of the heater. Start the heater and let run for 10 minutes.
3. Adjust the outlet manual balancing valve (A) until the proper temperature rise is achieved through the heater. (see Table 1) This establishes proper flow rate.
4. Fully open the manual bypass valve (B).
5. Again throttle back the outlet valve (A) to reduce the flow of water exiting the primary loop. This will increase the flow of heated water across the bypass and into the water heater inlet. Valve A is correctly adjusted when water temperature at the inlet of the heater is maintained between 130°F and 140°F after approximately 10 minutes of heater operation. (when heating a cold pool to operating temperature, valve A will have to be regularly readjusted as pool temperature increases to desired level. Otherwise, water temperature at the heater inlet will climb past the 140°F maximum when the desired pool temperature is achieved.) Outlet temperature display should equal the inlet temperature (130 to 140°) + the required temperature rise for the heater model.
6. Move Probe #1 from heater inlet to the pool filter loop upstream of the heater.

PRIMERA Model	Recommended Minimum Flow in Main Pool Loop	Primera Inlet to Outlet Temperature Rise After Manual Bypass Adjustment	Maximum Temp. from Pool before heating	Maximum Temp. To Pool after heating	Minimum Copper Pipe Size Required For Primera Connection *
400	85 gpm	23	108°F	130°F	2 inch
540	85 gpm	34	108°F	130°F	2 inch
750	170 gpm	21	108°F	130°F	2 inch
1000	210 gpm	23	108°F	130°F	2½ inch
1200	120 gpm	45	108°F	130°F	2 inch
1600	170 gpm	45	108°F	130°F	2 inch
2000	210 gpm	45	108°F	130°F	2½ inch

Table 1

* pipe sizes in Table 1 are for single water heater installations only. When multiple pool heaters are used, manifold piping that is shared by more than one heater must be sized to accommodate the anticipated maximum flow rate of all heaters connected to the manifold.

OPERATING SAFETIES

In addition to the temperature limits built into the PRIMERA water heater, the pool application guidelines include two additional temperature safeties. The 108°F US1 setting on the TempTrac control disallows the water heater to operate if the loop temperature prior to the heater is in excess of 108°. The 130°F thermostat downstream of the water heater interrupts power to the heater control circuit if the pool loop temperature reaches 130°F. This control is auto reset and will enable the control circuit when loop temperature drops below an adjustable differential.

SPA APPLICATIONS

Water heaters for spas are piped identically as general pool applications. The only exception to the instructions printed above is that the TempTrac setting for ST1 will be approximately 105°F. That ST1 setting and an Hy1 setting of -2 will maintain spa water between 103°F and 106°F. Temperatures in excess of 108°F are not recommended and the PRIMERA's TempTrac control should be adjusted as discussed in the Application Guidelines section of this instruction manual for a US1 setting of 108, thereby disallowing operation if water above 108°F is sensed in the pool filter loop upstream of the water heater.

Please refer to the PRIMERA General Installation and Maintenance Manual (form 34-50) for information regarding water temperature and scalding danger.

POOL CHEMICALS AND WATER HEATER LOCATION

Due to the highly corrosive environment created by pool chemicals, the PRIMERA water heaters should not be installed where these chemicals are stored. If fumes may be carried into the water heater during combustion, remote combustion air option must be specified. Failure of the PRIMERA heat exchanger or jacketing resulting from exposure to pool chemicals is not covered under the product warranty.

PIPING MULTIPLE HEATER INSTALLATIONS AND LEAD-LAG CONTROLS

If the water heaters are designed to be operated separately and never together, (100% redundancy only) a piping scheme similar to figure 2 is suitable. Otherwise, the heaters should be piped in a reverse-return arrangement as indicated in figure 3.

Riverside Hydronics does not recommend the use of lead-lag controls with multiple pool heaters. However, if the owner desires, lead-lag of multiple, single-stage pool heaters is accomplished by wiring the lead-lag control to the R1 and R2 terminals on each PRIMERA heater (terminals are located on the back of control box beneath the heater's top pan). Heaters ship with a jumper between R1 and R2 that must be removed if connecting to a lead-lag. The St1 control on the water heaters must be adjusted higher than the lead-lag setpoint. The lead-lag must be wired to each heater in series with a dedicated 130°F thermostat (see figure 1) Install the lead-lag sensor adjacent to the PRIMERA temperature probe in the pool filter loop.

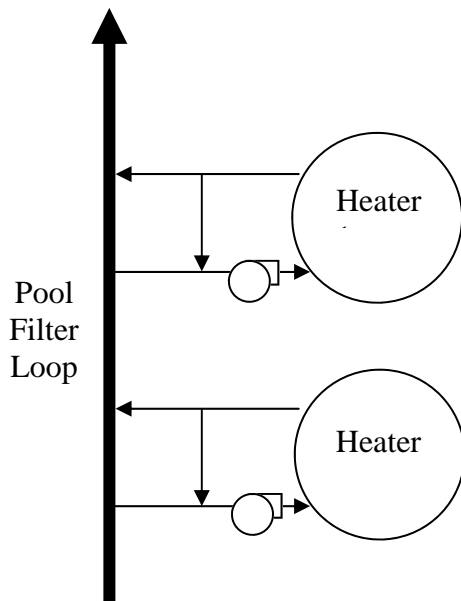

Figure 2 – Heaters never operate together

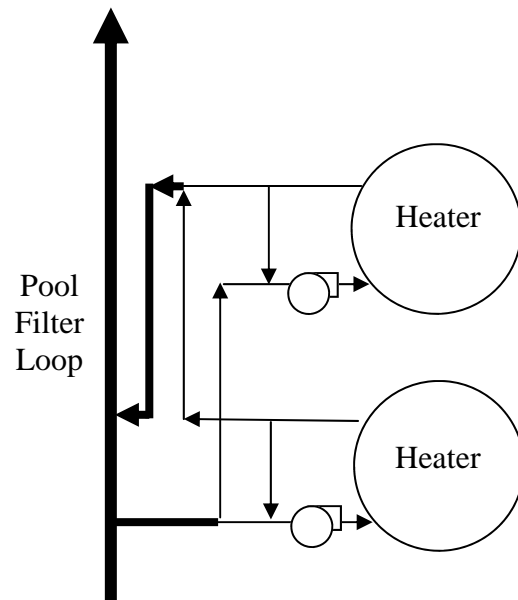

Figure 3 – Heaters operate together

Illustrations are simplified to emphasize the general piping concepts. Figure 1 must be referenced for details concerning probe locations and valve requirements. Shared piping (indicated by heavier lines in figure 3) must be sized to accommodate the total flow of all heaters.