



INSTALLATION & MAINTENANCE MANUAL

EPV SERIES CONDENSING WATER BOILER



Installation and service must be performed by a qualified service installer, service agency or the gas supplier.

IMPORTANT: THIS MANUAL CONTAINS INFORMATION REQUIRED FOR INSTALLATION, OPERATION AND MAINTENANCE OF THIS EQUIPMENT. READ AND FOLLOW THE INFORMATION IN THIS MANUAL AND ALL OTHER PROVIDED INSTRUCTIONS, LABELS AND MARKINGS BEFORE INSTALLING, OPERATING OR SERVICING THIS UNIT.

FOR YOUR SAFETY

- **Do not** store or use gasoline or other flammable vapors or liquids in the vicinity of this or any other appliance.

WHAT TO DO IF YOU SMELL GAS

- **Do not** try to light any appliance.
- **Do not** touch any electric switch; do not use any phone in your building.
- **Immediately** call your gas supplier from a neighbor's phone. Follow the gas supplier's instructions.
- If you cannot reach your gas supplier, call the fire department

This product contains, or may come to contain materials identified as carcinogenic, or possibly carcinogenic to humans. Before installing, servicing or removing this product, read and follow the supplied instructions.



WARNING: Improper installation, adjustment, alteration, service or maintenance can cause property damage, personal injury, exposure to hazardous materials or loss of life. Refer to the information contained in this manual. A qualified installer, service agency or the gas supplier, who must read and follow the supplied instructions before installing, servicing or removing this appliance, must perform installation and service. This appliance contains, or may come to contain materials that have been identified as carcinogenic, or possibly carcinogenic to humans.

WARNING: Do not use this appliance if any part has been under water. Immediately call a qualified service technician to inspect the unit and to replace any part of the control system, any gas controls and any other items affecting safe appliance operation and which has been under water. Failure to follow these instructions can cause property damage, personal injury, exposure to hazardous materials or loss of life.

TO THE INSTALLER: After installation, these instructions must be given to the equipment user or left near the appliance.

SPECIAL INSTRUCTIONS TO THE OWNER: Retain this manual for future reference. These instructions contain important information that will help you in maintaining and operating this appliance.



Riverside Hydraulics®, LLC - 990 Haltom Road - Fort Worth, Texas 76117 - Tel 1-800-990-5918

EPV SERIES CONDENSING WATER BOILER

INTRODUCTION

This manual covers installation, operation and maintenance on all Riverside Hydronics commercial boilers. Read all instructions thoroughly before attempting to start any unit.

CONTENTS

TOPIC	PAGE
General Safety Warnings and Codes_____	2-3
Typical Construction_____	4
Location and Installation_____	5
Clearances and Electrical Requirements_____	6
Venting Instructions_____	7
Air Inlet Duct Option_____	8
Vent Terminating_____	9-10
Gas Burner Construction_____	11
Start-up Procedures _____	12-15
Maintenance_____	16-17
Burner & Control Maintenance_____	18
Troubleshooting_____	20-22

PRODUCT SAFETY INFORMATION

REFRACTORY CERAMIC FIBER PRODUCT WITH CRYSTALLINE SILICA

WARNING: This product contains crystalline silica, which has been identified by the International Agency for Research on Cancer (IARC) as carcinogenic to humans. This product also contains refractory ceramic fibers, which have been identified by the IARC as possibly carcinogenic to humans. Avoid breathing fiber particulates and dust.

RISKS:

- Airborne fibrous insulation is a possible cancer hazard by inhalation.
- Airborne crystalline silica may cause silicosis (lung disease) by inhalation.
- May cause temporary irritation to eyes, skin, and respiratory tract.

PRECAUTIONARY MEASURES:

- Minimize airborne fibers with engineering controls.
- Use NIOSH/MSHA approved respirators as required (see MSDS).
- Wear long sleeved, loose-fitting clothing, eye protection and gloves.

FIRST AID MEASURES: (If any of the irritations listed persists, seek medical attention)

Eyes: Flush with water.
Skin: Wash with soap and warm water.
Ingestion: Do not induce vomiting. Get medical attention if gastrointestinal symptoms develop.
Inhalation: Remove to fresh clean air.

WARNING: If you are unfamiliar with the safe handling of refractory ceramic fiber products, or if you wish additional information prior to beginning any disassembly of the water heater or boiler that might expose refractory ceramic fiber materials, contact: Unifrax Corporation, 2351 Whirlpool Street, Niagara Falls, NY 14305-2413, 1-800-322-2293.

IDENTIFICATION OF REFRACTORY CERAMIC FIBER MATERIALS (RCF): The Combustion Chamber contains RCF materials which are located within the product and are not generally exposed except during service, disassembly or assembly.

IMPORTANT SAFETY NOTE

It takes only 5 seconds of skin contact with 140°F water to cause a second degree burn! You must protect against high water temperatures at all lavatories, tubs, showers and other points of hot water contact.

Accidental scalding from high water temperatures is a greater risk in some types of installations. Some examples are:

**HOMES FOR THE MENTALLY HANDICAPPED
HOMES FOR THE PHYSICALLY HANDICAPPED
HOSPITALS AND NURSING HOMES
ELDER CARE FACILITIES AND REST HOMES
ORPHANAGES AND CHILD CARE FACILITIES**

**OTHER INSTALLATIONS - WHERE RESPONSE TO CONTACT WITH HOT WATER
MAY BE SLOWER OR WHERE THE DANGER OF HOT WATER CONTACT IS
GREATER**

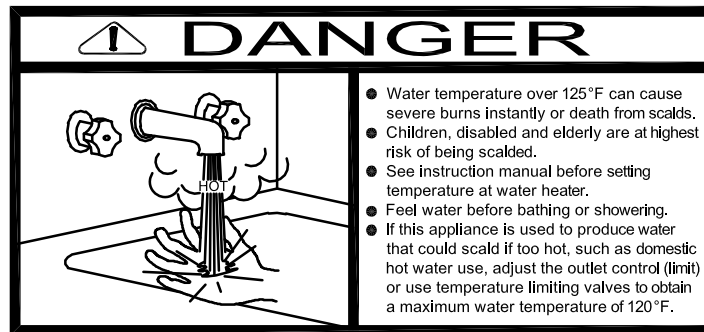

Thermostatically controlled mixing valves must be used in the design of the potable hot water system.

Potable hot water should be tempered to no more than 110°F when used for bathing or other personal uses.

Good engineering practice mandates the use of thermostatically controlled mixing valves set at 120°F or less to keep the delivered water temperature below scalding temperatures.

EPV SERIES CONDENSING WATER BOILER

TYPICAL CONSTRUCTION

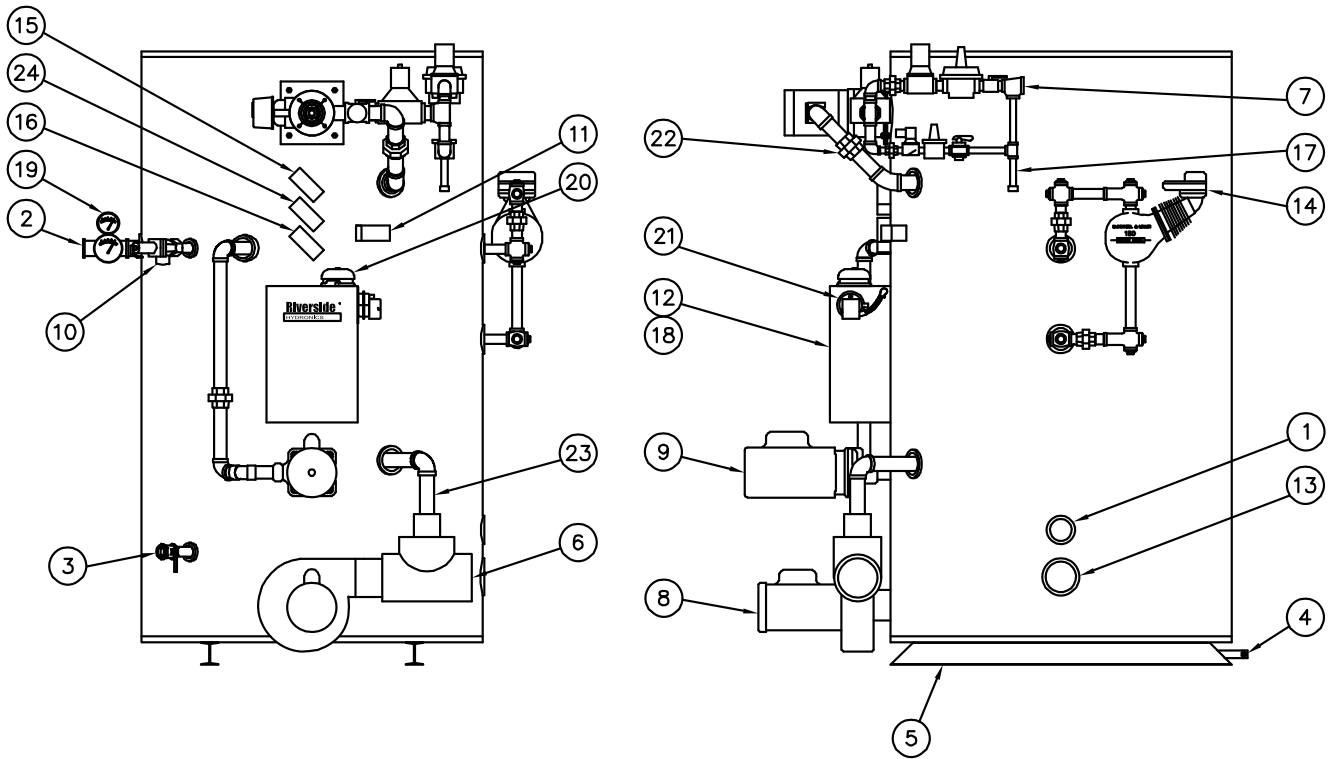

- | | |
|---|--|
| 1. Boiler water return | 13. Handhole access |
| 2. Boiler water supply | 14. Float LWCO (optional) |
| 3. Blowdown | 15. Manual reset temperature limiting device |
| 4. Condensate drain | 16. Operating control |
| 5. I-beam skid | 17. Drip leg |
| 6. Flue outlet | 18. Electronic LWCO control |
| 7. Gas inlet | 19. Temperature & pressure gauges |
| 8. Induced draft blower motor | 20. Alarm bell |
| 9. Circulating pump | 21. Differential air switch |
| 10. Safety valve | 22. Passive FGR duct (factory installed for Low NOx units) |
| 11. Electronic LWCO probe | 23. Passive FGR duct (field installed for Low NOx units) |
| 12. Control enclosure with switch(es) & fuse(s) | 24. Second stage thermostat (28 hp only) |

EPV SERIES CONDENSING WATER BOILER

CHECKING EQUIPMENT BEFORE YOU INSTALL

Inspect the unit completely upon receipt from the freight carrier before signing the bill of lading. Inspect the appliance and all accompanying parts for signs of impact or mishandling. Verify the total number of pieces shown on packing slips with those actually received. Contact the freight carrier immediately if any damage or shortage is detected.

WARRANTY

Factory warranty does not cover improper installation or operation. (See warranty for complete details).
Warranty exclusions include but are not limited to failure or malfunctions resulting from:

1. Failures to properly apply, install, operate, or maintain the appliance in accordance to printed instructions.
2. Abuse, alteration, accident, fire, flood and the like.
3. Sediment or lime buildup, freezing or any other conditions causing inadequate circulation.
4. Corrosive or contaminated atmosphere.

CODES

The equipment shall be installed in accordance with those installation regulations in force in the local area where the installation is to be made. These shall be carefully followed in all cases. Authorities having jurisdiction shall be consulted before installation is made. In the absence of such requirements, the installation shall conform to the latest edition of the National Fuel Gas Code, ANSI Z223.1 and with the National Electrical Code, NFPA 70. Where required by the authority having jurisdiction, the installation must conform to American Society of Mechanical Engineers Safety Code for Controls and Safety Devices for Automatically Fired Boilers, No. (CSD-1). All appliances conform to the latest edition of the ASME Boiler and Pressure Vessel Code, Section IV. Where required by the authority having jurisdiction, the installation must comply with the Canadian Association Code, CAN/CSA-B149.1 and/or B149.2 and/or local codes.

LOCATION

1. Locate the unit in a clean and dry area as close as possible to the greatest hot water usage and as near to gas, oil, steam, boiler water and/or electrical power as practical.
2. Install the unit on a firm, level foundation.
3. Locate the foundation on a pitched floor near a suitable drain, or make other provisions to prevent contact to areas of the building subject to water damage should the boiler or a water connection leak. The drain must be sufficient to contain water in excess of 210°F.

INSTALLATION

WARNING: Use industry standard safe rigging methods when attempting to lift or move this product. Failure to follow these instructions could result in property damage, serious injury or death. One common method includes the use of straps and spreader bars, lifting from the water heater base skid assembly.

1. Check the data decal on the boiler. Be sure the electrical, water, oil, or gas supply is adequate for the installation.
2. Carefully remove all shipping supports and bracing. (Float type devices have shipping plugs blocking the float).
3. Install shut-off valves and unions on the inlet and outlet water piping for servicing. Use caution when threading pipe nipples into tank connections to prevent cross threading, or over-tightening. Always use a back-up wrench on tank nipples when tightening unions, valves, etc.
4. Insulate hot water and return circulation lines. Insulate cold water supply lines if subject to freezing during shutdown periods. **IMPORTANT: Do not use the plumbing connected to the appliance as a ground for welding or any other purpose.**
5. The boiler is equipped with a temperature and pressure relief valve(s) rated for the input. Pipe the relief valve discharge to a suitable open drain. The drain pipe may not be smaller than the relief valve opening and must be secured to prevent it from lifting out of the drain under discharge pressure. Do not install valves or restrictions in the discharge line.
6. Pipe the drain valve to a suitable open drain.

EPV SERIES CONDENSING WATER BOILER

SERVICE CLEARANCES

Allow sufficient space to provide adequate clearances on all sides for service and inspection. Recommended clearance is 24" at the top and front, 18" at left and right sides of the appliance. Optional equipment may increase the clearance requirements. Allow sufficient space for installing and servicing connections such as water, gas, vent, combustion air, electrical, pump and other auxiliary equipment.

CLEARANCES TO COMBUSTIBLE SURFACES

The appliance must not be installed on a combustible floor, or on a non-combustible floor covering combustible material. Clearance to unprotected combustible material must be 8" minimum at top, sides and rear, and 24" minimum in front. Recommended access for service is 18" at sides and rear and 24" in front.

ELECTRICAL

WARNING: Turn off all electrical service to the appliance when accessing the controls located inside the control cabinet. The cabinet contains high voltage wiring and terminals. If the electrical service is not turned off and these wires or terminals are touched, a dangerous shock causing personal injury or loss of life could occur. Close the control cabinet before restoring electrical service to the appliance.

1. Wiring to the unit should conform to the National Electrical Code or the code legally authorized in your locality. A fused disconnect switch should be used for the boiler. When required, EPV boilers are equipped with step-down transformers located within the NEMA enclosure. This allows for an effective single point electrical connection to the boiler.
2. Be certain that high and low voltages are connected to the correct points.
3. When remote on/off or lead-lag enable operation is used, remove jumper from R1 and R2 and wire in series.
4. A proper earth ground for this unit must be provided. A single conductor ground wire pulled from the distribution panel to the sub panel (or some similar type) is recommended.

CAUTION: Use only copper wiring of proper sizing for incoming service. Damage resulting from use of aluminum wiring will be excluded from coverage under the warranty of this unit.

CONDENSATE NEUTRALIZATION & DISPOSAL

The EPV boiler can produce significant amounts of condensate because of their high efficiency. Condensate occurs naturally when water vapor in combustion gases is cooled below the dew point. Although only slightly acidic, EPV boiler condensate can be routed through an optional neutralization system to become pH neutral allowing for disposal into any drain or sewer system without concern for corrosion. A fitting should be provided in the venting to route any vent condensate away from the combustion blower. This can be accomplished by installing a tee in the vent not more than 18" from the combustion blower outlet.

Crushed limestone fills the condensate neutralization bath. Condensate slowly flows through the limestone bed and is neutralized thus avoiding chemical treatment or dilution using substantial quantities of tap water. If the condensate pH is lower than 4 when checked with a pH meter or pH paper, consult the factory for replacement treatment system. Condensate drainage from the POWER VT[®] boiler will only occur after a recovery run cycle. If no condensate is drained during this time, the drainpipe should be inspected for blockage. Should the heater not be installed on a housekeeping pad to ensure gravity drainage, a means of removing condensate, such as a pump, should be supplied in the system.

EPV SERIES CONDENSING WATER BOILER

VENTING INSTRUCTIONS

Vent this appliance in accordance with the latest edition of the National Fuel Gas Code and in accordance with the authority having jurisdiction. The EPV boiler is designed for operation with the 4", 5" or 6" positive pressure vent systems constructed of AL29-4C stainless steel.

WARNING: Do not use Type B vent or plastic vent of any type. These materials are not temperature or pressure rated for this appliance and could result in fire, injury, or death.

Vent System Design

The EPV boiler can be vented either vertically, through a ceiling or roof, or horizontally through a wall. From the vent pipe at the blower outlet, the vent can be routed in any direction except down. Like any closed piping system, the vent should maintain a downward slope toward the heater of at least ¼ inch per lineal foot of horizontal vent run to allow proper drainage of any accumulated moisture. Despite this flexibility, the following limitations and precautions must be observed. (Per NFPA Z22.1-1 "Provision shall be made to drain off and dispose of condensate from a venting system." A fitting, no more than 18" from the combustion blower, should be provided in the venting to route vent condensate away from the blower.)

Determination of Equivalent Length

Maximum equivalent length of vent must not exceed the length identified in Table 501-1:

Vent Pipe	Equivalent length		Maximum Vent Length	
	90° elbow	45° elbow	28 hp	All others
4	14	5	50	100
5	18	7	150	300
6	21	8	390	500

Table 501-1

- A. Add the total length of straight pipe (in feet).
- B. Multiply the number of 90° elbows used in vent system by the equivalent length of straight pipe specified in Table 501-1.
- C. Multiply the number of 45° elbows used in vent system by the equivalent length of straight pipe specified in Table 501-1.
- D. Add (A), (B) and (C) together to obtain the total feet of venting. This length must not exceed the maximum vent length identified in Table 501-1.

Example: A 4" venting system of 25 ft. of straight pipe and two 90° elbows.

- Total straight pipe = 20 feet.
- Number of elbows (2) x 14 = 28 equivalent feet of straight pipe.
- 20 feet plus 28 feet = 48 equivalent feet of venting.

This is an acceptable vent system.

NOTE: Consult the vent system manufacturer for specific design and installation details.

EPV SERIES CONDENSING WATER BOILER

Horizontal Venting Through a Wall

WARNING: Vent terminals for the flue and inlet air must use only vent terminations as supplied by the appliance manufacturer for these purposes. Failure to use the correct terminations could result in carbon monoxide poisoning causing personal injury or loss of life.

- The vent must extend one foot beyond the wall.
- The vent must not exit over a public walkway or over any other area where condensate or vapor could be hazardous.
- The vent must discharge at least three feet above grade of the level of normal snow accumulation.
- The vent must terminate at least four feet below, four feet horizontally from, or one foot above any building air inlet including doors and windows.

Vertical Venting Through a Roof

- The vent must extend upwards beyond nearby obstructions in accordance with Figures 501-2 and 501-3 (see page 9).

Venting of Multiple Units

- Multiple EPV models must not be vented into a common duct or breeching. Vent each unit independently in accordance with the instructions for either horizontal or vertical venting included above.

AIR INLET DUCT OPTION

WARNING: Vent terminals for the flue and inlet air must use only vent terminations as supplied by the appliance manufacturer for these purposes. Failure to use the correct terminations could result in carbon monoxide poisoning causing personal injury or loss of life.

Air inlet duct is defined as a means of ducting the outside combustion air to the burner for the purpose of avoiding corrosion that can be caused by contaminants which may be contained in indoor air and/or providing sufficient fresh air for proper combustion. If your POWER VT[®] boiler requires an air inlet duct, it can be connected directly to the burner inlet cap with self-tapping screws. No additional parts are necessary.

Constructing the Air Inlet Duct

- Use 6 inch, PVC sewer and drain pipe when constructing the combustion air duct for all POWER VT[®] boiler models. Single-wall galvanized may be used when PVC is not available. Care should be taken to tape all duct joints and connections.

When Ducting Vertically Through a Roof (Figure 501-4, Page 10)

- The duct must terminate with the UL listed vent termination provided by Riverside Hydronics.

When Ducting Horizontally Through a Wall (Figure 501-5, Page 10)

- The duct must extend one foot beyond the wall.
- The duct must terminate with the UL listed vent termination provided by Riverside Hydronics.
- The duct must terminate at least three feet above grade or the level of normal snow accumulation.

Maximum Equivalent Length of Duct

- The combustion air duct should be no more than 100 equivalent feet in length, but it may be of different configuration. See section on vent system design for details concerning combustion air duct construction.

EPV SERIES CONDENSING WATER BOILER

Typical Termination Locations for Vertical Vent Pipes

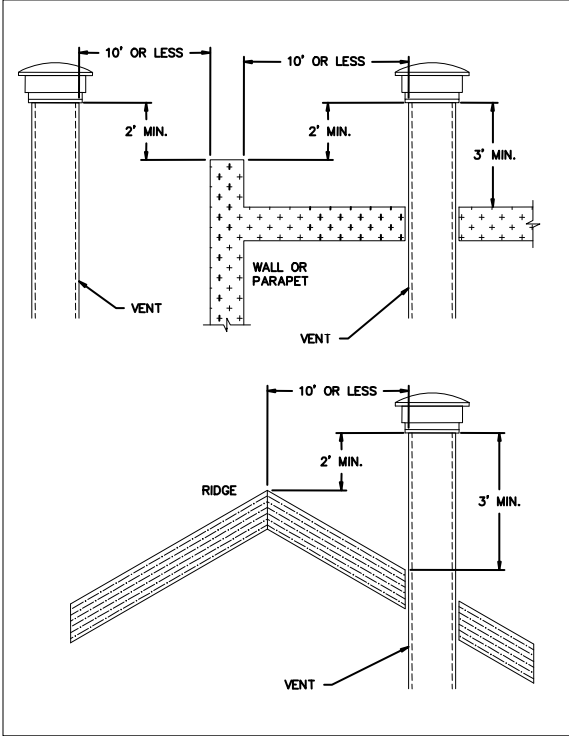

Termination of less than 10 feet
Figure 501-2

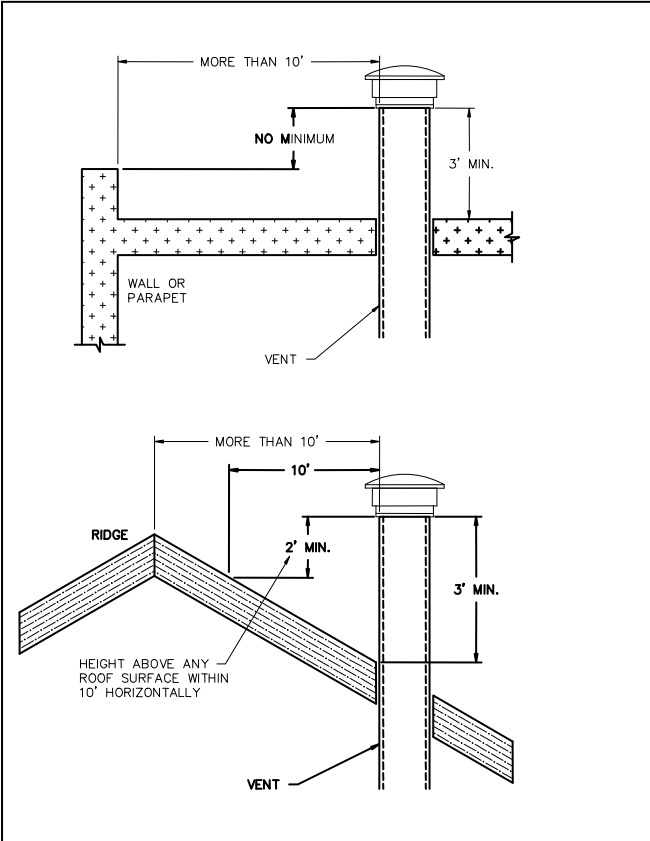

Termination of more than 10 feet
Figure 501-3

EPV SERIES CONDENSING WATER BOILER

Typical Locations for Vertical and Horizontal Vent Pipes

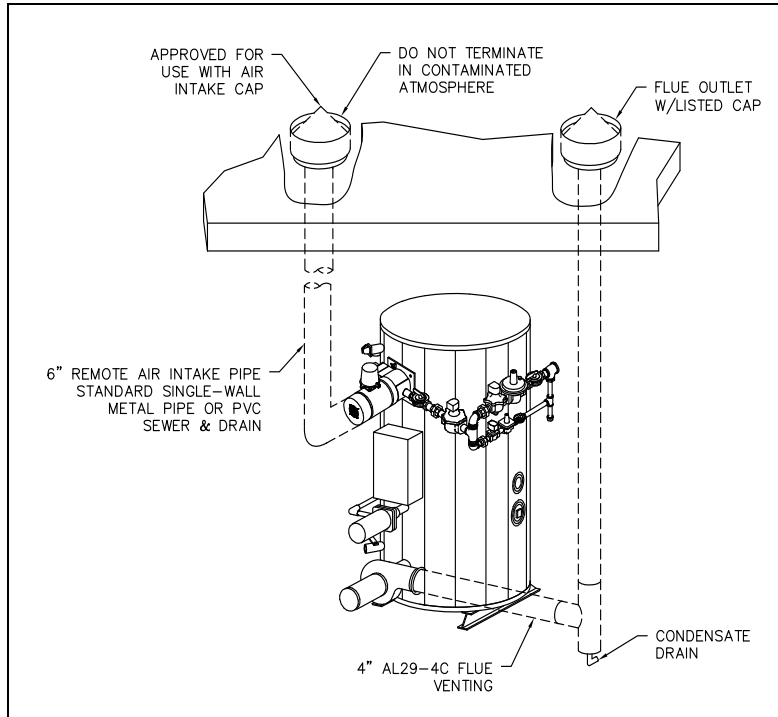

Vertical Venting
Figure 501-4

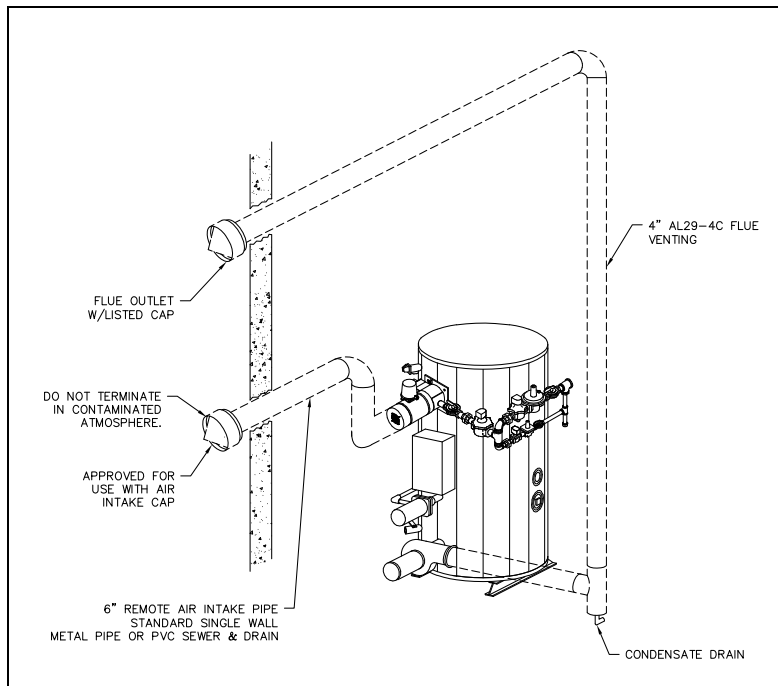

Horizontal Venting
Figure 501-5

- Install flue outlet and fresh air inlet with adequate separation to prevent recirculation of combustion products. Although the National Fuel Gas Code provides minimum clearances, use sound engineering judgment, considering prevailing winds, obstructions and the type vent termination used, etc.
- Either flue or remote air intake can be roof or side wall vented.
- Maximum length of remote intake ducting is 100 equivalent feet.
- See Table 501-1 (page 7) for maximum length of combustion venting.

EPV SERIES CONDENSING WATER BOILER

CARBON MONOXIDE WARNING: An annual or seasonal combustion checkout must be performed by a qualified service agency to ensure safe operation. Failure to maintain proper combustion can result in injury or death.

Typical Gas Burner Construction

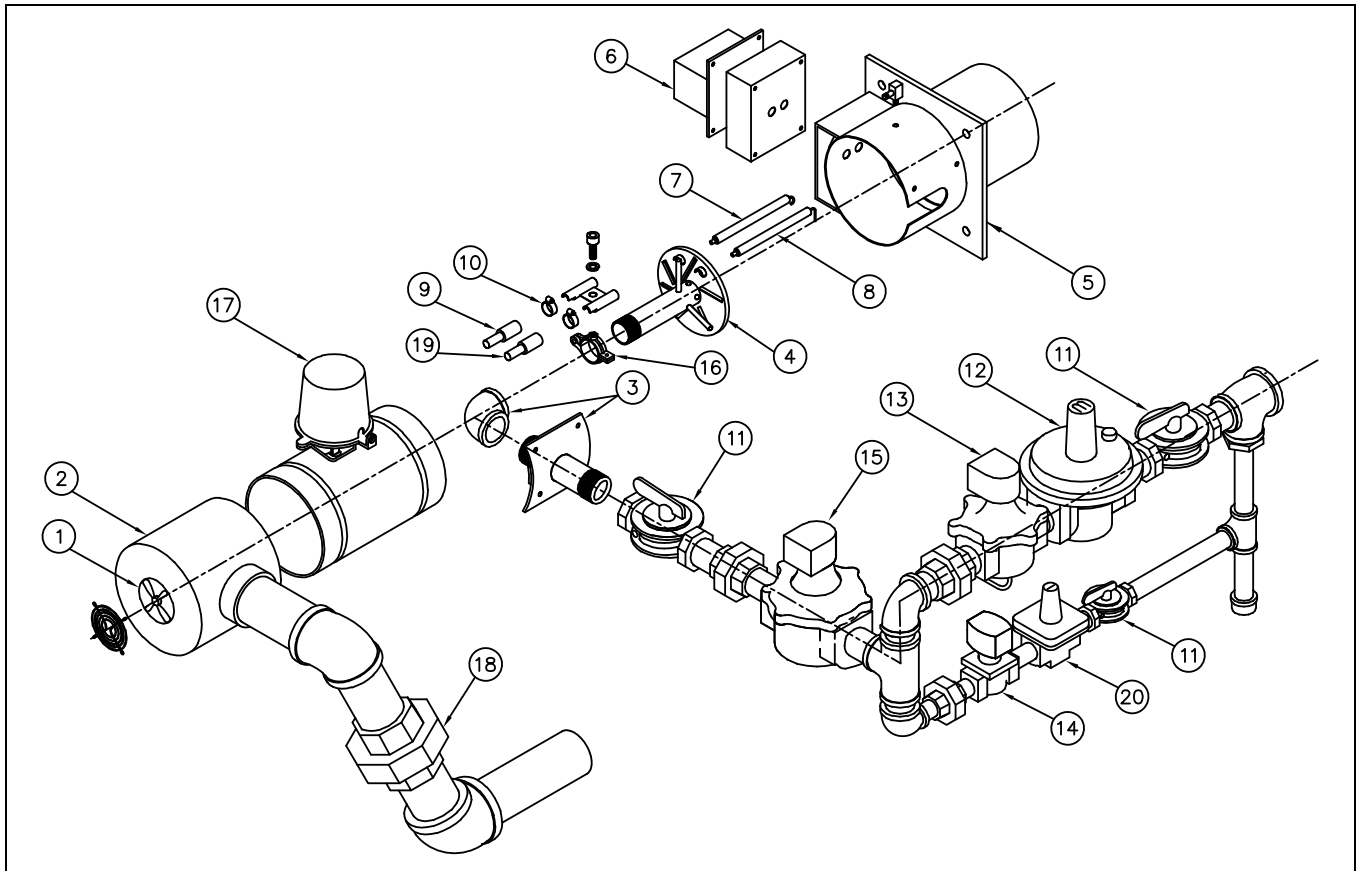

Figure 501-6

- | | |
|---|----------------------------------|
| 1. Static fan | 11. Manual shutoff valves |
| 2. End cap | 12. Main gas pressure regulator |
| 3. Gas nozzle assembly | 13. Main gas valve |
| 4. Pressure plate | 14. Pilot gas valve |
| 5. Blast tube & burner housing junction | 15. Auxiliary gas valve |
| 6. Ignition transformer | 16. Electrode clamp |
| 7. Ignition electrode | 17. Fresh air vent damper |
| 8. Flame sensing electrode | 18. FGR union with orifice |
| 9. Ignition electrode boot (red) | 19. Flame electrode boot (black) |
| 10. Electrode clamp | 20. Pilot gas pressure regulator |

EPV SERIES CONDENSING WATER BOILER

START-UP PROCEDURES

WARNING: Start-up should only be performed by a qualified technician.

CAUTION: Do not relight pilot or start burner with combustion chamber full of gas or oil vapor, or with very hot combustion chamber.

WARNING: You must connect the supplied gas train assembly to the burner union. Then connect the gas supply to the gas train. Do not connect the gas supply directly to this union. Failure to install the supplied gas train to the burner union before connecting the gas supply may result in uncontrolled gas flow into the appliance and/or the appliance area. Failure to follow this warning could result in fire or explosion causing property damage, personal injury or death.

1. The EPV gas valve and control train (gas train) provided with the appliance must be directly connected to the union piped out of the burner. After the gas train is attached to the burner, the gas supply can be connected to the gas shut-off valve (gas cock) at the gas train inlet. After gas plumbing is complete, verify the gas train is adequately supported and connect the conduit and multi-pin plug into the multi-pin receptacle in the gas train conduit box.
2. Carefully study the burner start-up information included in this manual.
3. Fill system tank with water. Some water boilers may be equipped with an optional air vent. If venting through the safety valve when filling the boiler, insure gags or fixtures are removed from the safety valve prior to start-up. Open the safety valve to allow air in the tank to escape.
4. Be sure all connections into the tank are tight, as leaks at tank fittings will damage the insulation.
5. The manual reset thermostat is a temperature limiting safety device set at 215°F; the operating thermostat is set at the factory at 180°F for on-off operation. For two-stage models, a second operating thermostat is used to control the second stage operation and should be set approximately 10°F below the primary operator. Adjustment may be made by turning the thermostat dial to the desired temperature.

CAUTION: Conduct the following gas train leakage test before start-up, at annual intervals and prior to investigating the cause of any reported occurrences of delayed ignition.

- Using an appropriate bubble detection solution, thoroughly coat all gas train pipe connections. If any bubbles are detected, the leaking connection must be tightened, recoated, and rechecked to assure stoppage of the leak.
- Attach a manometer to measure the gas pressure at the manual gas shutoff valve located just upstream of the gas train. Adjust gas train inlet pressure to the specified value (e.g. 14" W.C.), and tightly close the gas train manual shutoff valve closest to the burner.
- Reattach the manometer to the gas train manual shutoff valve at the burner and record the measured gas pressure in inches of water column (W.C.). Measure gas pressure again after 15 minutes. If gas pressure has increased 0.5" W.C. or more, the gas leak must be isolated to one or more of the operating gas valves. (For example, a solenoid actuated gas shutoff valve.) After any leaking valve is replaced, the reassembled gas train must be leak tested again before start-up is attempted.

WARNING: Turn off all electrical service to the appliance when accessing the controls located inside the control cabinet. The cabinet contains high voltage wiring and terminals. If the electrical service is not turned off and these wires or terminals are touched, a dangerous shock causing personal injury or loss of life could occur. Close the control cabinet before restoring electrical service to the appliance.

6. Remove enclosure panel cover on the boiler to expose control circuit. A wiring diagram, included in this packet, will show the controls used in our circuitry.

EPV SERIES CONDENSING WATER BOILER

7. Visually check that all components are intact and no damage has occurred during transit.
8. Check all connections within the control cabinet. A loose connection could cause intermittent shutdowns.
9. Some burners will use direct spark ignition. They may use a single gas pressure regulator and gas valve or multiple valves and regulators. On a call for heat, the motor starts, gas primary control is energized, the air vent damper opens and after a short delay (pre-purge), the gas valve(s) opens and ignition should occur.
10. **NOTE:** Do not tamper with or readjust program dipswitch settings. This will cause the control to become inoperable. Damage resulting from tampering will be excluded from coverage under the warranty of this unit.
11. Connect a test meter to the control for reading the flame response signal.
12. **NOTE:** Some controls read the flame signal in micro amps and some in volts DC. The M series control has two terminals marked for reading volts in DC.
13. **CAUTION:** Be sure the tank is filled with water. Dry firing can destroy the boiler.
14. Check the gas pressure before start-up, using a U-tube manometer or a 0 to 28" W.C. pressure gauge for inlet gas pressure. (This is the pressure measured before all components in the gas train.) The manometer must stay connected throughout the testing, as the inlet pressure must be monitored during the firing of the burner. Record static pressure; it must not exceed 14" W.C. Pressures above this could cause damage to the diaphragm in the gas valve or pressure regulator.
15. Connect a manometer to the manifold test port at the shutoff valve closest to the burner. Turn off main gas shutoff valve. Turn unit on using the rocker switch on the side of the control enclosure assembly. If the operating control switches are closed, the burner blower should come on and pre-purge begins.
16. If nothing happens, check the control to be sure it is not in the tripped position and reset it by pushing the flame safeguard reset button. The burner should pre-purge at least thirty seconds.
17. When the blower motor starts, the air damper will open and the airflow proving light on the MEC120 should be on. This indicates a positive airflow condition. If the air proving light is not on, check the air-proving switch for operation. To adjust the air-proving switch, turn the adjustment screw counter-clockwise until the air proving light comes on, then turn the screw one turn counter-clockwise. If the gas valves open and close intermittently during normal operation, turn screw one half turn counter-clockwise until this condition ceases. This procedure should be followed with every burner.

This section is for single-stage and two-stage firing:

After purging is complete, terminal 3 on the flame control energizes the pilot valve and terminal 4 energizes the ignition transformer. The pilot is then established. The VDC reading on the meter should read a steady 6-10 VDC; 6 VDC is the minimum flame signal for it to operate reliably. If the pilot fails to light during the initial period, it is probably due to air in the line. The control will lock out and require reset.

Once the flame is established, the ignition transformer will de-energize and terminal 5 will energize the main valve. At this point the boiler is operating at maximum firing rate (high fire). In order to insure the boiler is operating at the rated input, it is necessary to check the manifold gas pressure (measured at the pressure tap on the gas valve closest to burner). The manifold gas pressure should be adjusted at main gas regulator to the factory recommended pressure shown on tag attached to gas train. Do not screw the adjusting nut of the regulator in beyond point where no further increase in manifold pressure is noted. While firing, check the gas pressure at the inlet of the gas train. The minimum supply pressure requirement on the Power VT boiler is 4.5" W.C. supply unless otherwise specified on the data plate. It should be a minimum of that shown above with the boiler running at high fire. This is recorded as inlet flow pressure. It is important incoming pressure does not fall below this minimum or nuisance control lockouts could occur.

EPV SERIES CONDENSING WATER BOILER

This section is for two-stage firing only:

After adjusting the high fire manifold gas pressure, it is now important to check the operation of the first stage (low fire). There is a toggle switch on the control cabinet labeled "Auto/Low Fire". Switch from the auto position to low fire and the main valve will de-energize shutting off the high fire gas supply and the air damper will close reducing the airflow to a minimum. Once the boiler is at low fire the manifold gas pressure can be adjusted as described in the previous paragraph but using the pilot gas regulator instead of the main gas regulator. Proceed to paragraph 10 to test and document combustion results for low fire and high fire.

18. Check flue gases with an electronic flue analyzer to make final settings of gas pressure regulator.
19. The readings need to be taken from a hole in the vent several inches downstream of the fan outlet connection.
20. Insert 0-6" W.C. manometer into the test opening in the vent. Pressure in stack should not exceed 2" W.C.
21. When water in tank is above 120°F, insert analyzer or O₂ testing in test opening; take O₂ reading in percentage.
22. Increase manifold gas pressure at the main gas pressure regulator taking O₂ reading at each adjustment of gas regulator until optimum O₂% (5-7%) is reached. If O₂% decreases, reduce the gas pressure to last reading where the greatest reading is achieved.
23. CO should not exceed 200 ppm. A reading greater than 200 ppm indicates lack of air. Reduce manifold gas pressure slightly and take readings until CO is within proper range. Optimum reading is no CO.
24. If manifold pressure was changed during startup, take a final CO and O₂ reading.
25. Record CO₂ and NO_x if applicable. See paragraph 27 if NO_x measurement is required.
26. Insert vent temperature gauge in test opening and read gross vent temperature; maximum gross stack is to be 275°F. If an excessively high gross vent temperature is recorded; consult the factory.
27. When the Power VT Boiler is equipped for Low NO_x operation, it may be necessary to measure the NO_x levels in the flue products for compliance verification. The NO_x concentrations are measured in ppm (parts per million). When documenting the measurements on the startup report, be sure to note whether or not the readings are corrected to a baseline O₂ level. If during the course of startup the NO_x levels do not meet your locally mandated requirements, it may be necessary to change the FGR (flue gas re-circulation) orifice. This orifice is contained in the FGR union shown on page 11, Figure 501-6. This union may contain two or more orifices. This allows the removal of one or more of the orifices in order to increase the flow of FGR and thereby reduce NO_x in the flue products. If the FGR orifice is changed for any reason, the startup procedure in paragraph 18-26 should be repeated.
28. Check each operating and limit control to be sure they function properly by lowering and raising the temperature setting on each of the controls, causing burner to cycle on and off.

NOTE: During the initial firing of the burner, smoke that is not related to the burner will be emitted from the heater. This is normal during "burn in" and could possibly continue for several hours.

EPV SERIES CONDENSING WATER BOILER

Record the following information for future use:

1. **Manifold gas pressure:** _____ " W.C.
2. **Vent pressure:** _____ " W.C.
3. **O₂ reading:** _____ % (5-7%)
4. **CO₂ reading:** _____ % (8-9%)
5. **CO reading:** _____ ppm (less than 300 ppm)
6. **NO_x reading:** _____ ppm
7. **Vent temperature:**

 Gross _____ °F.

 Less ambient _____ °F.

 Net _____ °F.

EPV SERIES CONDENSING WATER BOILER

MAINTENANCE

CARBON MONOXIDE WARNING: An annual or seasonal combustion checkout must be performed by a qualified service agency to ensure safe operation. Failure to maintain proper combustion can result in injury or death.

CAUTION: Be sure manual valves and burner electrical switch are turned off before removing any part for service or cleaning. Do not push relay contacts in manually; accidental opening of main automatic valve can result. Ensure there is no pressure on the vessel prior to disassembly of any water carrying component to prevent serious injury.

1. A preventive maintenance is recommended to assure a long, trouble-free life of the boiler. Refer to ASME Section VII for a comprehensive plan for boiler operation, maintenance and lay-up.

A table of periodic safety inspections is attached to this manual for ease of reference by the building service technician or licensed equipment operator (Table 501-2, page 19). Since boiler designs vary, only some of these listed inspections may be appropriate for your particular model.

2. Proper water treatment is critical to prevent corrosion as well as to reduce scale, both of which will reduce the life of the boiler. Hydronic heating systems, steam heating systems and process steam systems all have different treatment requirements. The makeup of the water, just as the blowdown, will vary with each application. Rely on the recommendation of the water consultant.

SINCE RIVERSIDE HYDRONICS CANNOT CONTROL THE USE OF THE BOILER, WATER CONDITIONS OR MAINTENANCE, THE WARRANTY ON THE BOILER DOES NOT COVER POOR PERFORMANCE, STRUCTURAL FAILURE OR LEAKING DUE TO AN EXCESSIVE ACCUMULATION OF SCALE. HOWEVER, SHOULD A FIRETUBE LEAK FOR ANY REASON, CONSULT THE FACTORY FOR INSTRUCTIONS.

3. Examine the venting system at least monthly for proper connections, alignment, or the presence of corrosion. If corrosion appears, the boiler must not be operated until the corroded vent section(s) is replaced.
4. Oil the blower motor and wipe oil and dust from the burner at regular intervals. The static fan will collect dust from the air during operation. Clean the screen and fan blades if necessary. The burner should be cleaned each year. Inspect all parts and make replacements when necessary. Check wiring for loose connections and burned wires.

WARNING: Turn off all electrical service to the appliance when accessing the controls located inside the control cabinet. The cabinet contains high voltage wiring and terminals. If the electrical service is not turned off and these wires or terminals are touched, a dangerous shock causing personal injury or loss of life could occur. Close the control cabinet before restoring electrical service to the appliance.

5. Periodic inspections and check-out of the burner ignition system, control system and fuel valve operation (for tight close-off) should be made. Refer to the burner installation instructions for inspection recommendations.
6. Inspect operating controls to ensure they are level, especially those containing mercury switches. Make sure connecting tubing is not kinked or damaged on remote bulb thermostats.
7. The pressure safety valve should be checked at regular intervals by manually opening the valve. The openings inside the valve may become restricted by a buildup of scale and become inoperative. If the valve does not open and close properly, it must be replaced. Shut down boiler, relieve internal pressure, and replace safety valve with a like kind or one meeting the requirements stated on the rating decal located adjacent to the safety valve mounting location.

CAUTION: The safety valve is a *primary* safety device.

EPV SERIES CONDENSING WATER BOILER

MAINTENANCE (con't)

8. The need to periodically check water level controls and waterside of the pressure vessel cannot be over emphasized. Most instances of major boiler damage are the result of operating with low water or the use of untreated (or incorrectly treated) water.

Every boiler is equipped with an electronic low water cutoff. This device senses continuity between a probe located in the top of the tank and the water to verify the presence of water. It is important to check the operation of this device periodically.

9. This boiler may be equipped with a float-type low water cutoff. Since low water cutoff devices are generally set by the original manufacturer, no attempt should be made to adjust these controls to alter the point of low water cutoff. If a low water device should become erratic in operation or if it's setting changes from previous established levels, check for reasons and correct; repair or replace as required.

The controls operation may be checked by stopping the water supply to the boiler while the burner is operating at low fire. While under constant attendance allow the water to lower at a normal rate. If a control does not break the circuit to stop the burner at the proper point, then **SHUT DOWN THE BURNER IMMEDIATELY**.

Do not restart until all cross connecting piping is checked for obstructions. Also check the float bowl. If these are clean, repair or replace the control. Repeat the above test to insure proper operation prior to returning the boiler to service.

Remove the pipe plugs from the tees and crosses and make certain the cross connecting piping is clean and free of obstructions. Controls must be mounted in a plumb position for proper performance.

Determine piping is vertically aligned after shipment and installation and throughout the life of the equipment. The operation of the electronic low water cutoff may be checked in the same manner, by bypassing the function of the float low water cutoff.

10. It is important to blowdown the float low water cutoff devices when supplied. It is recommended that a short blowdown be conducted daily. Float low water cutoffs should be equipped with test-n-check valves to allow blowdown of low water cutoff without requiring complete drainage of the boiler.
11. A boiler used for heating or seasonal loads or for standby service may have an extended period of non-use. Special attention must be given so that neither waterside nor fireside surfaces are allowed to deteriorate from corrosion.

There are two methods of storage – wet or dry. Your water consultant or feedwater treating company can recommend the better method, depending upon circumstances in a particular installation. Section VII of the ASME Code also contains information relating to laying up a boiler.

12. Extended shutdown of the boiler and restarting are as follows:
 - Turn off all power and fuel supplies.
 - Enter boiler into dry storage.
 - Tag power switch(s) that fuel is off and tank is in storage condition.
 - Remove tank from storage and turn fuel and power switch(es) on to start. Reset all controls and conduct startup of the boiler as discusses previously.

EPV SERIES CONDENSING WATER BOILER

BURNER AND CONTROL MAINTENANCE

13. Remove the flame safeguard control from its base. Check the connections in control mounting base; loose connections can cause nuisance shutdowns.

NOTE: Always secure gas lines and tag "Out of Service" before servicing burner nozzle or electrodes.

14. Pull the nozzle assembly to check the flame and ignition electrodes. This is done by first disconnecting the gas train by breaking at the unions. Then remove the nozzle assembly with the electrodes and pressure plate attached. Disconnect the electrode wires. Take care not to damage the insulation on the electrodes.
15. With electrodes exposed, check for the proper settings as in Figure 501-7 below. Check for any hairline cracks in the insulators. Should replacement of burner electrodes be required, certain procedures must be followed. In all cases, removal of electrodes is accomplished by loosening the electrode mounting clamps. Draw electrodes out of the nozzle assembly through the holes in the pressure plate.
16. Inspect electrodes for cracked ceramic or loose retaining studs that hold the wire within the ceramic. Select the proper pressure plate hole to place each electrode and insert electrode through hole, retaining stud end first.
17. Tighten electrode-mounting clamp slightly until electrode ceramics are seated firmly and completely in the mounting bracket without gaps between ceramics and mounting bracket at the bearing faces.
18. Measure and set electrodes according to Figure 23-7 below. After gaps and setting are complete, fully tighten the electrode-mounting clamp. Do not overtighten or ceramic insulation may crack.
19. Replace nozzle assembly; be sure to connect the flame and spark rod wires before installing nozzle assembly fully into blast tube. Check connections on the ends of the flame and spark rod wires for good contact. Look for properly stripped wire ends. Be sure connections are firmly attached to the flame and ignition rod ends. Insulating boots can give a false feeling of proper seating. **DO NOT MOVE ELECTRODES.** Be careful not to bump electrodes. Check fan wheel for free rotation.
20. Reinstall gas nozzle assembly.

Pressure Plate Set Up and Tolerances

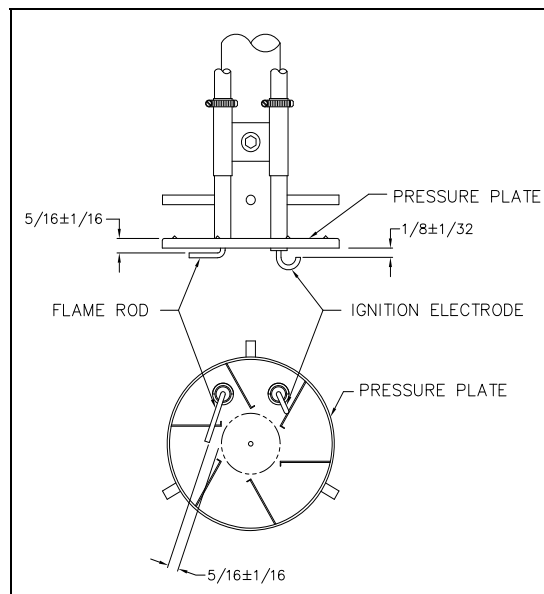

Figure 501-7

EPV SERIES CONDENSING WATER BOILER

MAINTENANCE & SAFETY INSPECTION REPORT

DATE	BURNER INSPECTION	COMBUSTION ANALYSIS	TANK INSPECTION	TANK FLUSH & CLEANOUT	TANK FITTING INSPECTION	VENT INSPECTION	THERMOST AT INPSECTION	GAS TRAIN LEAK TEST
Recommended Inspection Intervals	YEARLY	6 MONTHS	6 MONTHS	3 MONTHS	6 MONTHS	YEARLY	YEARLY	YEARLY

TABLE 501-2

EPV SERIES CONDENSING WATER BOILER

TROUBLESHOOTING SUGGESTIONS GAS BURNER

1. BURNER FAILS TO START:

- a) Defective on/off switch. Replace switch.
- b) Control circuit has open control contact. Check limits, low water cutoff, and others as applicable.
- c) Bad fuse or switch opens on incoming power source. Correct as required.
- d) Flame safeguard control safety switch tripped out. Reset and determine cause of apparent flame failure.
- e) Loose connections or faulty wiring. Tighten all terminal screws and consult wiring diagram furnished with the heater.
- f) Flame safeguard control starting circuit blocked due to flame relay being energized. Possible defective scanner or flame rod – replace. Possible defective amplifier – replace. Scanner actually sighting flame due to leaking fuel valve – correct unwanted flame cause. Defective flame safeguard control – replace.
- g) Defective blower motor. Check for free rotation of fan wheel. Repair or replace.
- h) Air proving switch is not properly adjusted. Adjust per instructions; page 13, paragraph 17.
- i) Defective circulation pump. Repair or replace.
- j) Regulator vent line(s) plugged. Remove blockage.

2. OCCASIONAL LOCKOUTS FOR NO APPARENT REASON:

- a) Gas pilot ignition failure. Check to see that ignition is instant and flame signal readings are stable and above minimum values. Use an incline manometer to make certain pressure is as recommended.
- b) Loose or broken wires. Check all wire nut connections and tighten all terminal screw connections in panel and elsewhere as appropriate.
- c) With flame safeguard controls that incorporate the air flow switch in the non-recycling circuit, ensure that when main flame lights, the air flow switch is not so critically set as to allow occasional momentary opening of the air switch contacts.
- d) Occasional low supply voltage. Contact local utility to correct. Make certain the burner control circuit transformer (if supplied) is correct of the voltage and power (AC) being supplied.
- e) Occasional low gas supply pressure. Contact local utility to correct.
- f) Regulator vent line(s) plugged. Remove blockage.
- g) Excessive flue gas recirculation, causing unreliable or unstable operation. Reduce the orifice size in the FGR union and readjust the gas regulators to achieve proper excess air in combustion.

EPV SERIES CONDENSING WATER BOILER

3. BURNER MOTOR RUNS, BUT PILOT DOES NOT LIGHT:

- a) Gas supply to burner shut off. Make sure all manual gas supply valves are open. Automatic high-pressure valve at meter such as "Sentry" type tripped shut due to high gas pressure. Reset valve and correct cause for trip out.
- b) Pilot solenoid valve not opening. Listen and feel for valve actuation. Solenoid valve not being powered. Check electrical circuitry. Replace coil of entire valve if coil is burned out.
- c) Defective gas pilot regulator. Replace.
- d) Gas pressure too high or too low at pilot orifice (if supplied). Check orifice size in gas pilot assembly. Replace if incorrect. Readjust pressure as required.
- e) Defective ignition transformer. Replace. Incorrect ignition electrode settings. Readjust as required.
- f) Defective component within the flame safeguard control. Replace as required.
- g) Airflow switch not making circuit. Check out electrically. Defective airflow switch. Replace. If switch negative pressure sensing tube out of position. Reposition as necessary.
- h) Regulator vent line(s) plugged. Remove blockage.

4. BURNER MOTOR RUNS AND PILOT LIGHTS, BUT THE MAIN GAS FLAME IS NOT ESTABLISHED:

- a) Main shutoff or test cock closed. Check to make certain fully open.
- b) Pilot flame signal reading too low to pull in flame safeguard relay. Readjust as required.
- c) Defective automatic main or auxiliary gas shutoff valves. Check electrical circuitry to valves. Replace valves or correct circuitry as required.
- d) Main diaphragm shutoff valve opening too slowly. Adjust bleed on valve.
- e) Defective flame safeguard control or plug on amplifier. Check and replace as required.
- f) Main gas pressure regulator atmospheric vent line obstructed. Correct.
- g) Defective main gas pressure regulator. Replace. Misadjusted main gas pressure regulator. Readjust to meet required operational values.
- h) Polarity reversed on incoming power (S89 control only). Correct.
- i) Regulator vent line(s) plugged. Remove blockage.

5. CARBON MONOXIDE READINGS ON GAS FIRING:

- a) Flame impingement on "cold" heat transfer surfaces caused by excessive firing rate. Reduce firing rate to correct input volume.
- b) Incorrect gas/air ratios. Readjust burner to correct CO₂ / O₂ levels, eliminates all CO formation.
- c) Excessive flue gas recirculation, causing insufficient excess air for complete combustion. Reduce the FGR orifice size and readjust the gas regulators to achieve proper excess air in combustion.

EPV SERIES CONDENSING WATER BOILER

6. GAS HIGH FIRE INPUT CANNOT BE ACHIEVED:

- a) Gas Company pressure regulator or meter operating incorrectly, not allowing required gas pressure at burner train inlet. Contact Gas Company to correct.
- b) Gas cock upstream of train inlet not fully open. Check and correct.
- c) Gas line obstructed. Check and correct.
- d) Gas train main and/or lead test cocks not fully open. Check and correct.
- e) Gas supply line between gas company regulator and burner inlet too small. Check supply pressure at meter, determine pressure drop and increase line size as required, or raise supply pressure to compensate for small line. Do not raise pressure so high that under static (no flow) conditions the pressure exceeds the maximum allowable pressure to the gas train components on the burner.
- f) Automatic gas valve not opening fully due to defective operation. Replace gas valve.
- g) Defective main gas pressure regulator. Replace.
- h) Incorrect spring in main gas pressure regulator. Replace as required.
- i) Main gas pressure regulator vent line obstructed. Check and correct.
- j) Normally open vent valve (if supplied) not closing when automatic gas valves open. Replace vent valve, if not closing fully.
- k) Second stage thermostat is not properly adjusted. Second stage thermostat should be set approximately 10°F below the primary operating thermostat.

Additional troubleshooting information can be found in the Flame Safeguard bulletin with the burner.