

EMX SERIES • Gas-Fired WATER BOILER

1,000,000 to 1,400,000 Btu/h (25 to 34 hp)

MODEL NUMBER ►	25 WB250A-MXG	29 WB250A-MXG	34 WB250A-MXG
Boiler Horsepower	25	29	34
Input Btu/h	1,000,000	1,200,000	1,400,000
Output Btu/h	820,000	984,000	1,148,000
* Min. inlet flow gas press. " W.C.	4.5	6.0	6.0
Max. static gas pressure " W.C.	14	14	14
A Cold Inlet - NPT	3	3	3
B Hot Outlet - NPT	3	3	3
C Drain - NPT	1	1	1
D I - Beam Skids	3 x 45	3 x 45	3 x 45
E Overall Depth	63	63	63
F Overall Height	82	82	82
G Flue Outlet Diameter	10	12	12
H Gas Inlet - NPT	2	2	2
Motor HP 120 V, 1Ø, 60 Hz.	1/2	1/2	1/2
Motor Amps	10	10	10
L Height to Outlet	73	73	73
M Height to Inlet	36	36	36
N Width	45	45	45
P Skid Centers	27	27	27
R Front to Back	52	52	52
Approx. Shipping Weight - lbs	1870	2000	2120

Output rating based on 82% combustion efficiency.

* The information presented is for natural gas 0.6 S.G. and std. gas train – For operation with propane (LP gas), consult the factory.

FOR GAS PRESSURES OUTSIDE OF THIS RANGE, CONTACT YOUR RIVERSIDE HYDRONICS REPRESENTATIVE.

Dimensions are in inches unless otherwise specified.

For standard and optional equipment, see form 34-606.

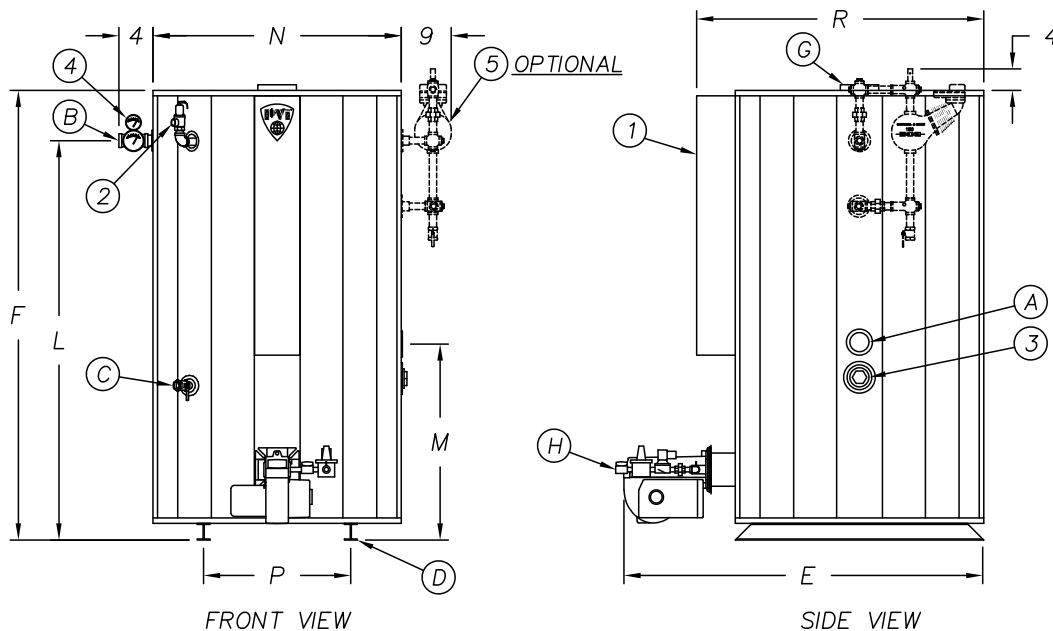

VENTING REQUIREMENTS:

-.02" TO -.06" W.C. (NEGATIVE PRESSURE).
TYPE B VENTING.
THE ENTIRE VENT SYSTEM SHOULD NEVER BE SIZED BASED UPON THE VENT CONNECTION DIAMETER EXCLUSIVELY.
FOR PROPER VENT SIZING, CONSULT THE NATIONAL FUEL GAS CODE UNDER "FAN-ASSISTED".

MINIMUM CLEARANCES:

8" FROM TOP, SIDES AND REAR, 24" FROM FRONT.
ADDITIONAL CLEARANCE FOR SERVICE IS RECOMMENDED.

ELECTRICAL REQUIREMENTS:

1. Control Enclosure
2. ASME Pressure Relief Valve
3. 3" NPT Handhole
4. Temperature & Pressure Gauges
5. Float Low Water Cut-off (Optional)

CONTROL VOLTAGE: 120V, 1Ø, 60 HZ., 2 AMPS
SEE ABOVE CHART FOR BLOWER MOTOR AMPS

