

PRIMERA[®]

HEATING BOILERS / HOT WATER SUPPLY BOILER ASME H STAMP, 160 MAWP

MODEL NO.: 1600 B

INPUT: 1,600,000 Btu/h
OUTPUT: 1,360,000 Btu/h

Design flow rate through the boiler: 61 gpm with 18 feet of head loss

Weight: 625 lbs.

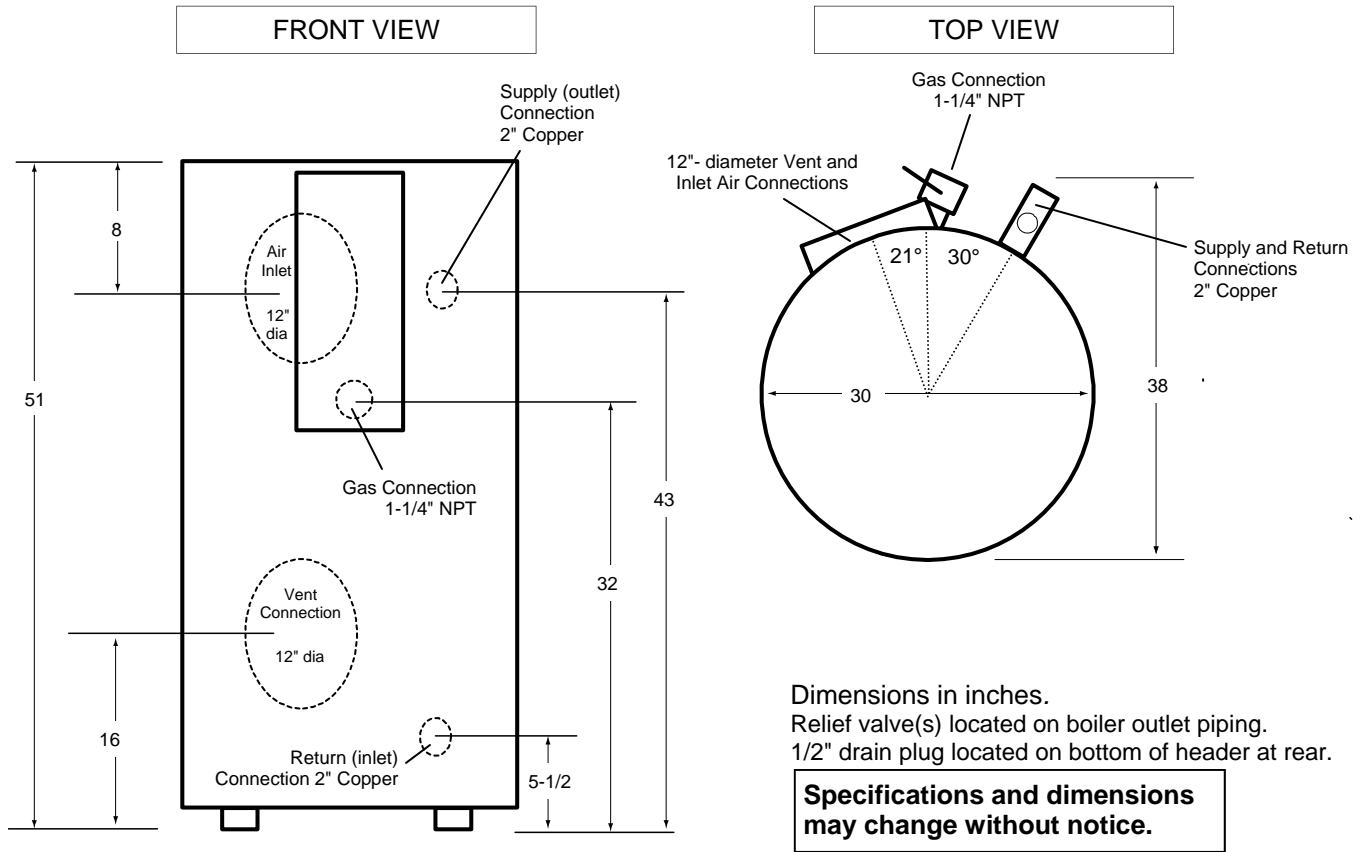

Installation Clearances:

Listed for 1" clearance from combustible materials.

24" required for service clearance at top and front. Do not install on combustible floor.

Local installation codes take precedence over appliance's clearance listings.

Electrical Requirements: 120 VAC, 60 Hz., 10 amps (does not include optional circulator)

Gas Pressure Requirements: Minimum Flow 4.5" W.C., Maximum Static Pressure 10.5" W.C.

LP Gas Pressure Requirements: Minimum Flow 11" W.C., Maximum Static Pressure 13" W.C.

Vent Requirements: -.01 to -.08 inches W.C. Category I, Type B (barometric damper supplied)

Vent must be sized using National Fuel Gas Code guidelines. Do not size the entire vent system based solely upon the vent connection diameter at the appliance.

Category III sidewall vent also available. Consult representative or installation manual for details.