

**Storage Tanks for Hot Water Supply Boilers**  
**Glass-Lined - 80 to 175 Gallon**  
*Supplied through a partnership with RHEEM Manufacturing*

Model Number	Gallons Storage	Construction	Maximum Allowable Working Pressure (psi)	Dimensions in inches				Water Connections (all locations) inches NPT	Shipping Weight lbs.
				A	B	C	D		
ST 80	80	standard	150	58-3/8	24-1/2	13-1/4	6-1/4	2	220
ST 80A	80	ASME	125	58-3/8	24-1/2	13-1/4	6-1/4	2	260
ST 120	119	standard	150	59-1/4	28-1/4	11-1/8	4-1/8	2	300
ST 120A	119	ASME	160	59-1/4	28-1/4	11-1/8	4-1/8	2	340
ST 175A	175	ASME	150	67-1/4	32-1/4	12-1/2	5-1/2	2-1/2	600

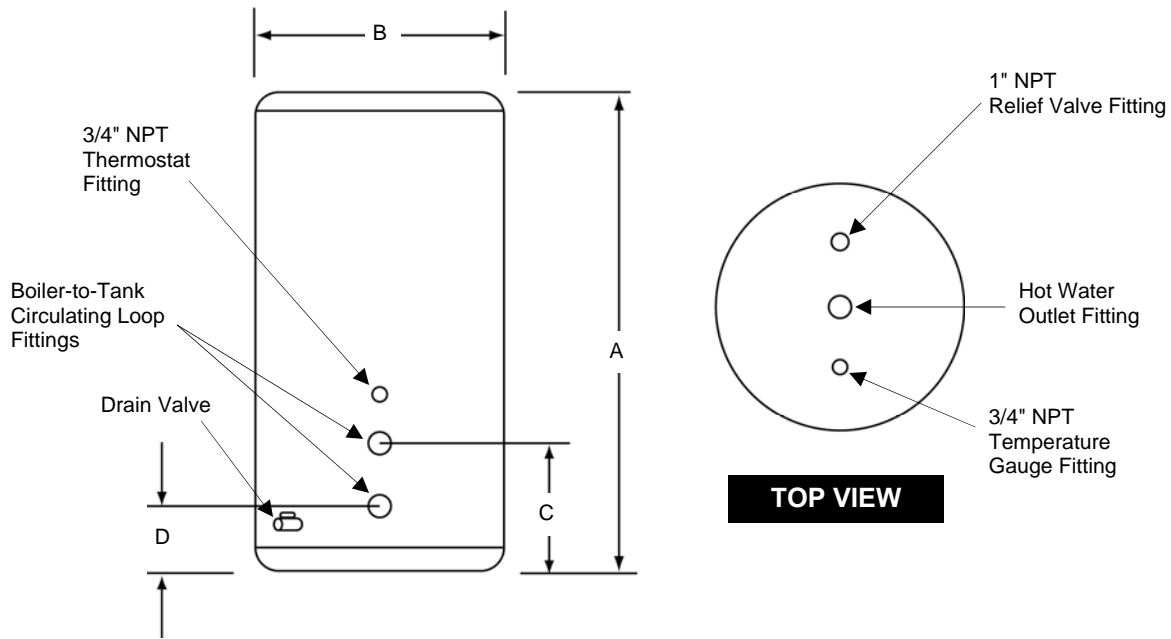

Standard Equipment

- Two coats of high-temperature porcelain enamel on tank interior
- Two heavy-duty magnesium anode rods
- 2" rigid foam insulation (meets ASHRAE 90.1 standards)
- Baked enamel steel jacket
- Drain valve
- 5-year limited warranty
- Immersion well for single PRIMERA water heater thermister (shipped loose for field installation)

Optional Equipment

- Tank thermostat
- Temperature gauge
- Temperature and Pressure relief valve